

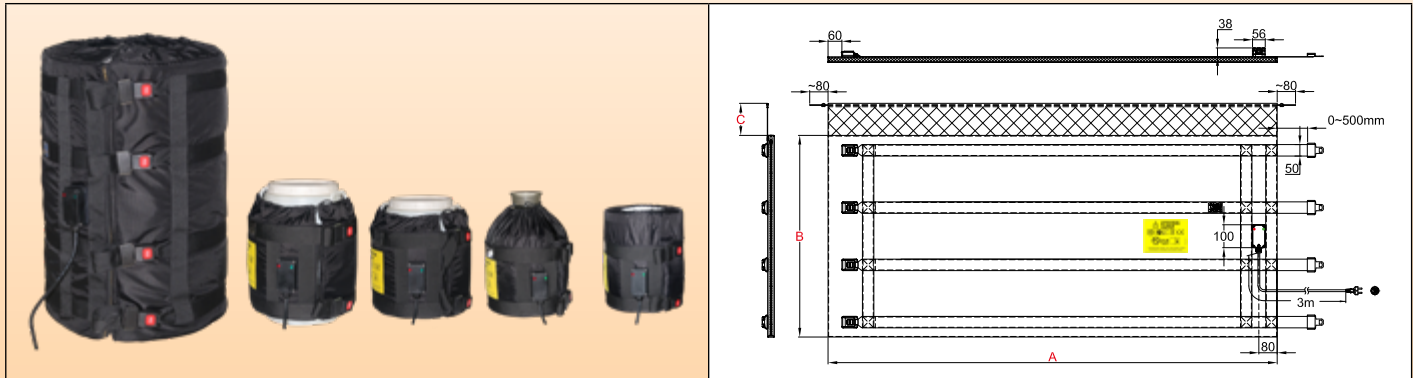

Fixed temperature setting flexible jacket heaters for glass or plastic containers

Because of permanent improvement of our products, drawings, descriptions, features used on these data sheets are for guidance only and can be modified without prior advice

Containers material	Maximum temperature limited to :	Tightening	Thermostat	Insulation thickness	Type
Glass, Plastic	65°C	Nylon straps and metal buckle	Surface mounted, fixed setting temperature 65°C	10mm	9VJV6



Main Features

This **economical version** of flexible jacket heater is used to reduce viscosity or to melt soaps, animal or vegetable fats, varnishes, oils, food or chemical products.

It is the most efficient solution for heating glass or plastic containers. These models are available for containers of 18L/20L (5 US gallons), 23L/25L (6 US gallons), 30L (8 US gallons), 60L (15 US gallons) and 110 liters (30 US gallons). The jacket heater covers almost the entire surface and is surmounted by a soft collar "a scarf" preventing it from sliding down. They can be made with two power levels (0.05W/cm² and 0.1W/cm²) and two thicknesses of insulation (10mm in standard and 20mm in option). In these models the surface temperature is limited to 65°C to prevent deformation or melting of plastic containers, or temperature stress breaking of glass containers.

When they are used with an insulated lid and an insulated pedestal, their energetic efficiency can rise 90%.

Technical characteristics

The heating element of the flexible jacket heater consists of a network of silicone insulated heating wires shielded by a metal braid, taken under a cover sewn in PU and Teflon coated polyester fabric. A temperature-resistant NBR-PVC foam insulation is inserted between the heating network and the outer wall. This insulating foam has an insulation coefficient (Lambda λ) of 0.039W/m.K, and this makes it possible to divide the energy losses by 3 compared to jacket heaters insulated with mineral wool or carbon fiber felt of the same thickness. Adjustable **metal** buckles allow quick assembly and disassembly and efficient clamping on the container. Their mechanical strength is exceptional.

Fabric covering:

- Internal heating face: Teflon coated polyester fabric,
- External side: waterproof PU coated polyester fabric.

Thermal insulation:

NBR-PVC foam, with closed cells and high temperature resistance, thickness 10mm. This thickness is chosen for its great flexibility, important on small containers.

Heating element:

Silicon rubber insulated heating wire with metal braid providing mechanical protection against puncturing and good grounding.

Temperature control:

A temperature limiter is incorporated in the heating net to limit the surface temperature to 65°C. Two pilot lamps indicate the presence of voltage and the heating function.

Warning: these models start to heat up as soon as you connect them to the power supply.

Connection cable:

Insulated rubber power supply cable, for industrial environments, 3 x 1mm² length 3m, Euro plug. UL plug on request.

Mounting on containers:

These jacket heaters feature nylon straps with quick-release adjustable buckles for adjustment to the diameter of the container, and a soft fabric collar without thermal insulation named scarf. This flexible scarf can be used to hold in place an insulating lid in the case of cylindrical containers.

Options:

- 0.135W/cm² surface load for fast heating. See technical introduction.

Fixed temperature setting flexible jacket heaters for glass or plastic containers



- Power supply 110/115V
- Power cord with industrial plug 2-pole + earth 16A CEE (IEC60309)
- Lids and insulated pedestals: see the accessories pages.

Compliance with standards: CE compliant. TUV certificate: EEC Low Voltage Directive (LVD) and EMC directive 2004/108/EC, and CE marked accordingly.

Main references (see the technical introduction for the liquids heating time)

References*	Insulation (mm)**	Volume, US gallons	Volume, Liters	Dia. (mm ± 12; Inch ± ½")	Height A (mm/inch)	Flat length B (mm/inch)	Scarf C (mm/inch)	w/cm ² (W/in ²)	Watt	Voltage V
9VJV6300958150HC	10	5	18/20	280 (11)	300 (11.8)	950 (37.4)	150 (5.9)	0,05 (0.32)	150	220/240
9VJV6301028165HC	10	6	25/30	280 (11)	300 (11.8)	1020 (40.2)	150 (5.9)	0,05 (0.32)	165	220/240
9VJV6401398275HG	10	15	50/60	410 (16.1)	400 (15.7)	1390 (54.7)	100 (3.9)	0,05 (0.32)	275	220/240
9VJV6731558550HG	10	30	110	460 (18.1)	730 (28.8)	1550 (61)	100 (3.9)	0,05 (0.32)	550	220/240
9VJV6300958300HC	10	5	20/25	280 (11)	300 (11.8)	900 (35.4)	150 (5.9)	0,1 (0.64)	300	220/240
9VJV6301028330HC	10	6	25/30	280 (11)	300 (11.8)	1020 (40.2)	150 (5.9)	0,1 (0.64)	330	220/240
9VJV6401398550HG	10	15	50/60	410 (16.1)	400 (15.7)	1390 (54.7)	100 (3.9)	0,1 (0.64)	550	220/240
9VJV6731558A10HG	10	30	110	460 (18.1)	730 (28.8)	1550 (61)	100 (3.9)	0,1 (0.64)	1100	220/240

* For these products supplied with UL plug and not Euro plug, replace the 15th character by X.

** Models with 20mm insulation, replace 9VJV6 by 9VJF6

Because of permanent improvement of our products, drawings, descriptions, features used on these data sheets are for guidance only and can be modified without prior advice